

PK 45.002 TEC 5 | PK 48.002 TEC 7

HIGHEST TECHNOLOGY IN THE 50 MT-CLASS

LIFETIME EXCELLENCE



LIFTING CAPACITY DIAGRAMS

C

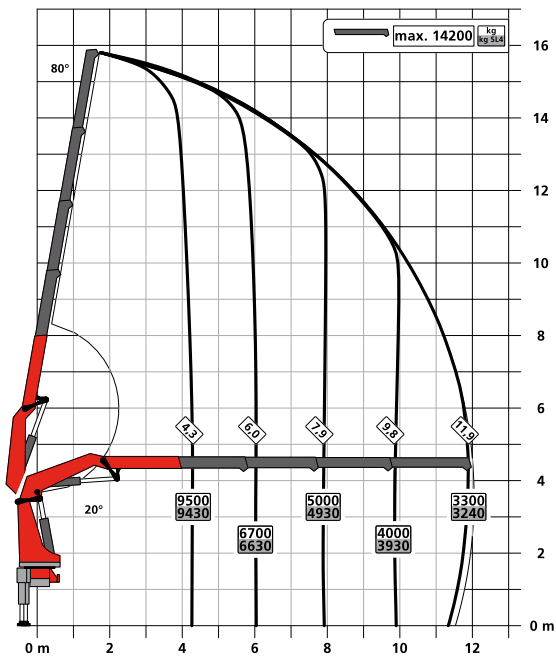

D

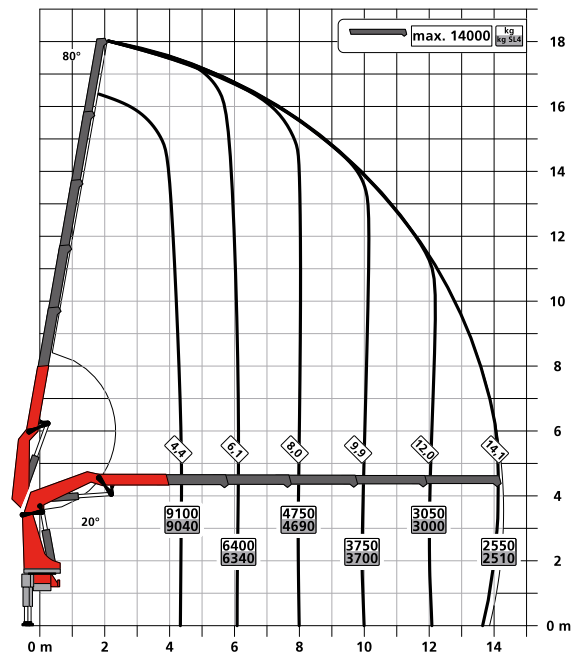

F

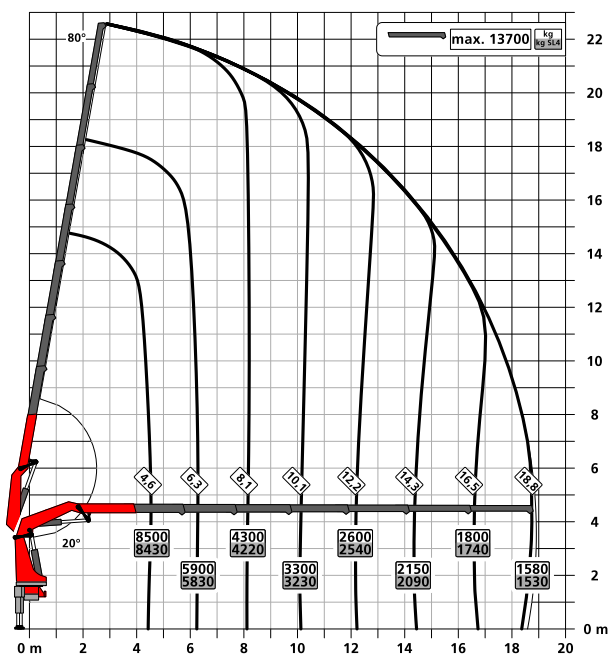

G

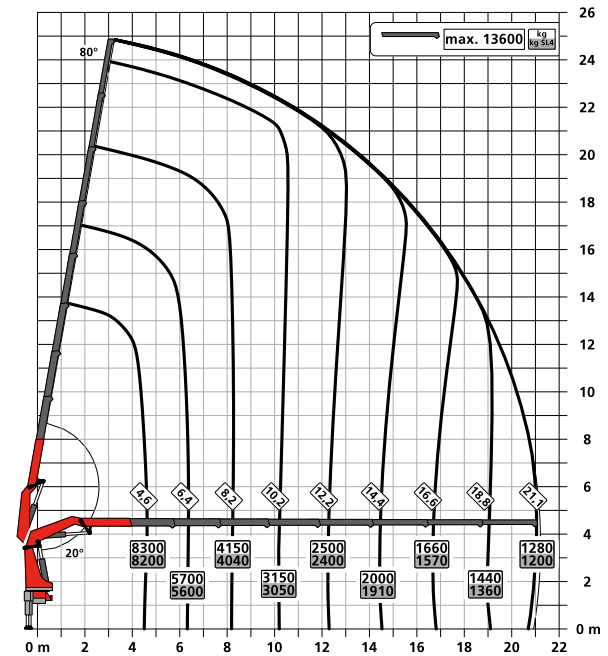

E

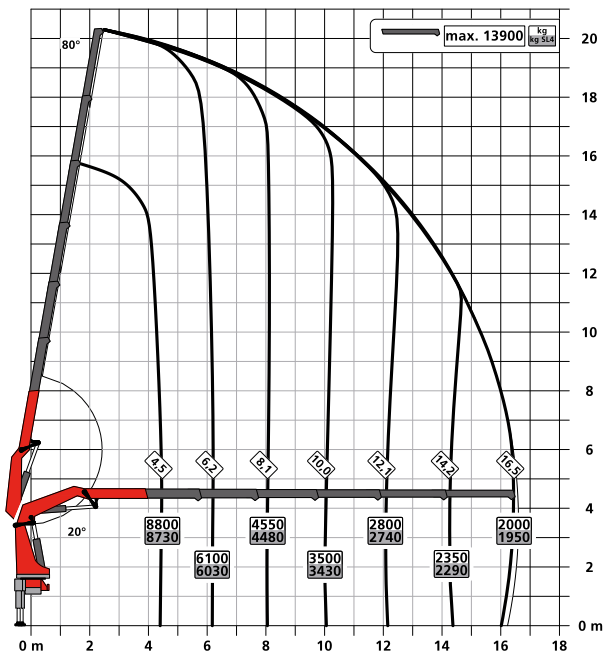

MODEL LINE TEC 5

- Power Link Plus
- Paltronic
- S-HPLS
- Scanreco P3
- Soft Stop
- Optional:
 - HPSC-Plus LOAD
 - AOS
 - SRC
 - PJ075 with DPS-P
 - PJ090 with DPS-P
 - PJ150 with DPS-P
 - Rope winch: 2.5t or 3.5t

TECHNICAL SPECIFICATIONS

EN 12999 HC1 HD4/S1

Max. lifting moment	43.7 mt/428.8 kNm	316,240 ft.lb
Max. lifting capacity	15600 kg/153.0 kN	34,400 lb
Max. hydraulic outreach	21.2 m	69' 7"
Max. outreach	25.9 m	84' 11"
Max. outreach (with fly jib)	33.9 m	111' 3"
Slewing angle	continuous	
Slewing torque with 1 slewing drive	4.0 mt/39.2 kNm	28,910 ft.lb
Slewing torque with 2 slewing drive	5.2 mt/51.0 kNm	37,610 ft.lb
Stabiliser spread	7.8 m	25' 7"
Fitting space required (std.)	1.43 m	4' 8"
Width folded	2.55 m	8' 4"
Max. operating pressure	370 bar	5,365 psi
Recommended pump capacity	from 90 l/min to 120 l/min	23.8 US gpm to 31.7 US gpm
Dead weight (std.)	4300 kg	9,480 lb

LIFTING CAPACITY DIAGRAMS

C

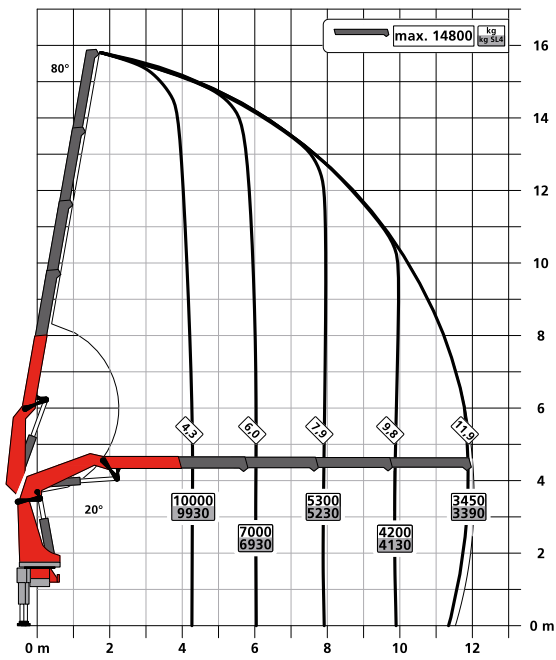

D

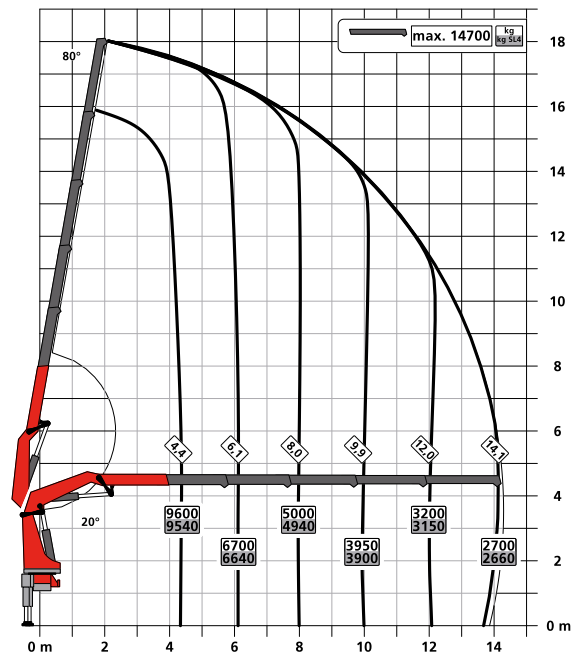

F

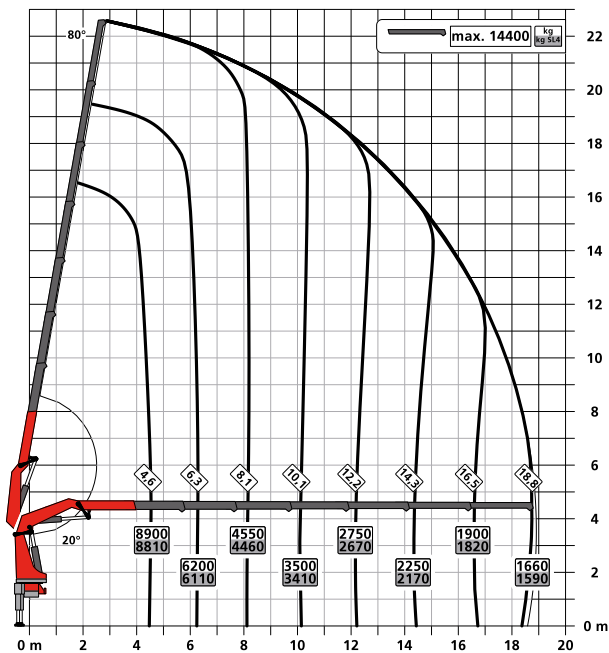

G

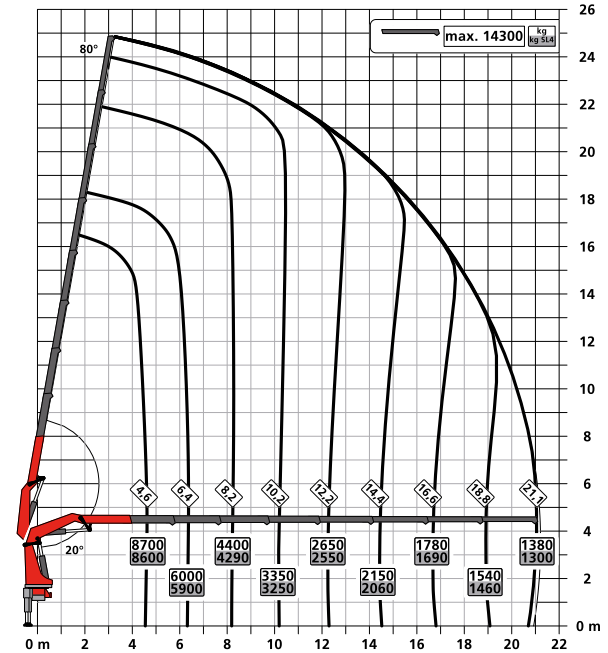

E

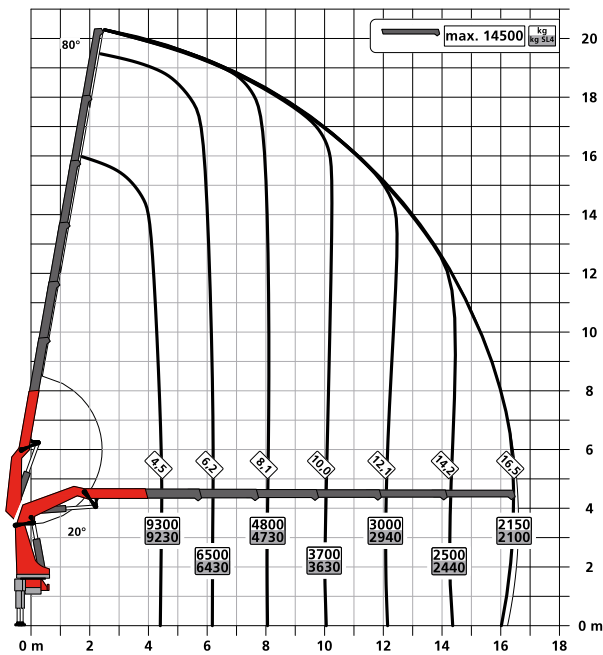

MODEL LINE TEC 7

- Power Link Plus
- Paltronic
- S-HPLS
- PALcom P7
- Soft Stop
- Optional:
 - HPSC-Plus LOAD / GEOM / FSTAB
 - P-Fold
 - AOS
 - RTC
 - SRC
 - PJ075 with DPS-C
 - PJ090 with DPS-C
 - PJ150 with DPS-C
 - Rope winch: 2.5t or 3.5t

TECHNICAL SPECIFICATIONS

EN 12999 HC1 HD5/S1

Max. lifting moment	45.7 mt/448.3 kNm	330,620 ft.lb
Max. lifting capacity	16500 kg/161,9 kN	36,380 lb
Max. hydraulic outreach	21.2 m	69' 7"
Max. outreach	25.9 m	84' 11"
Max. outreach (with fly jib)	33.9 m	111' 3"
Slewing angle	continuous	
Slewing torque with 1 slewing drive	4.0 mt/39.2 kNm	28,910 ft.lb
Slewing torque with 2 slewing drive	5.2 mt/51.0 kNm	37,610 ft.lb
Stabiliser spread	7.8 m	25' 7"
Fitting space required (std.)	1.43 m	4' 8"
Width folded	2.55 m	8' 4"
Max. operating pressure	385 bar	5,585 psi
Recommended pump capacity	from 90 l/min to 120 l/min	23.8 US gpm 31.7 US gpm
Dead weight (std.)	4300 kg	9,280 lb

STRONG WITH FLY JIB

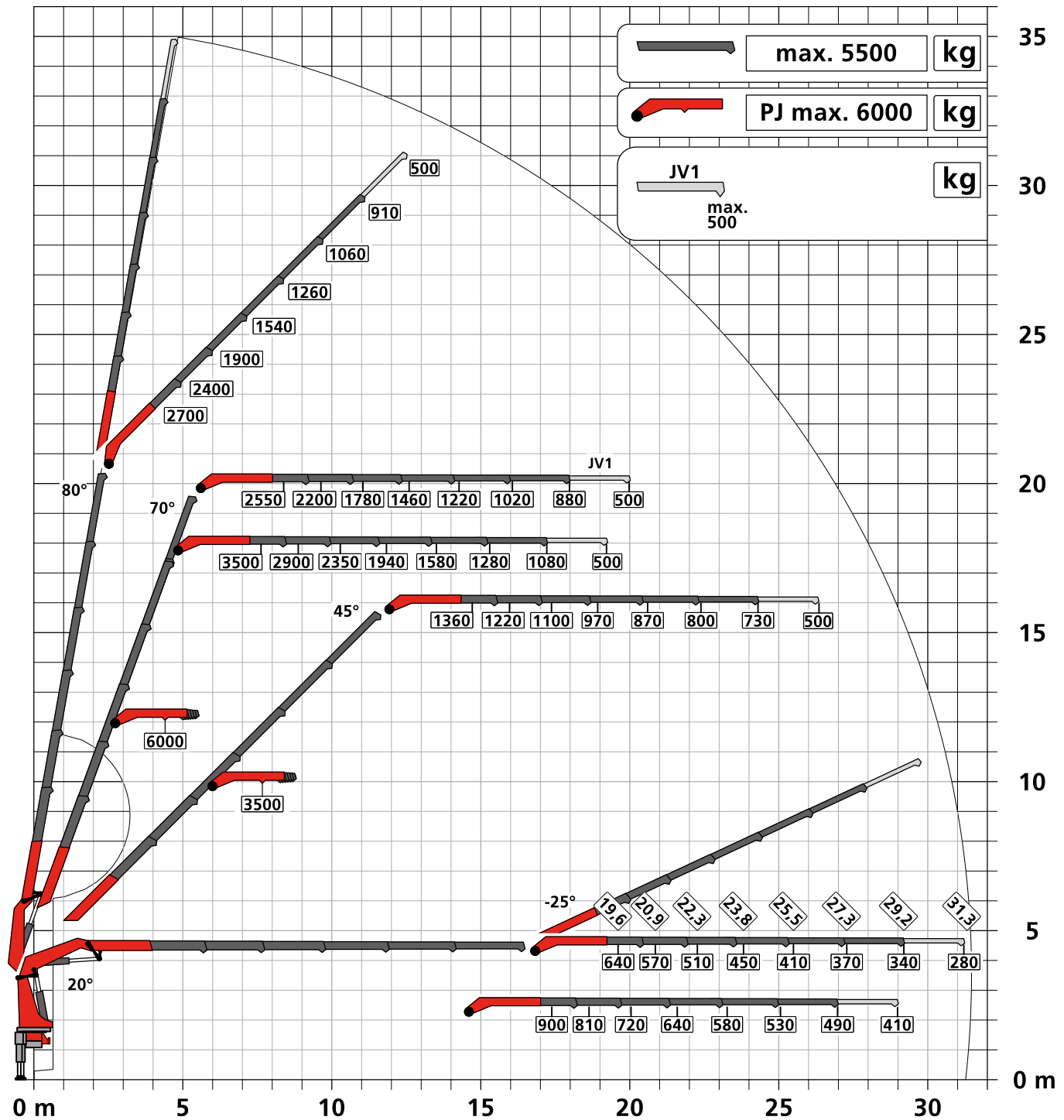

FIRST-RATE IN DESIGN AND PERFORMANCE



P-Profil

Rigid and light

The polygonal or drop-shaped P-Profile is especially rigid and simultaneously light weight design perfection.



P-FOLD*

Perfect set-up by fingertip control

The new assistance system makes folding and unfolding an easy job for the crane operator. This significantly increases operator comfort and prevents costly damage.



HPSC-Plus*

Maximum utilization of the working range

The modular system HPSC-Plus offers three modules expanding HPSC. Thanks to load detection, length measurement system or stabilizer force detection, lifting capacity can be maximized.



DPS-Plus / DPS-C*

More efficient fly jib operation

The Dual Power System allows multiple uses of the crane both for large outreaches as well as for heavy load operation.

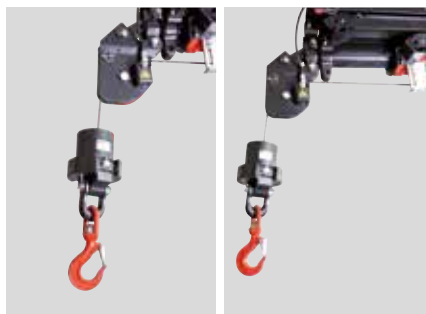

SRC and RTC*

More comfort in rope winch operation

SRC (Synchronised Rope Control) maintains a constant distance between the pulley head and the hook block, while RTC (Rope Tension Control) is automatically controlling the rope tension. Two systems, which are particularly valuable in terms of operator friendliness and efficiency of operations.



MEXT and WEIGH*

Systems for easy handling

MEXT includes mechanical extensions into the overload protection while WEIGH allows to weigh loads. The result: lower effort for the operator in daily working tasks.

